

100MBA90B20 MAGNEBRAKE PERFORMANCE & OUTLINE

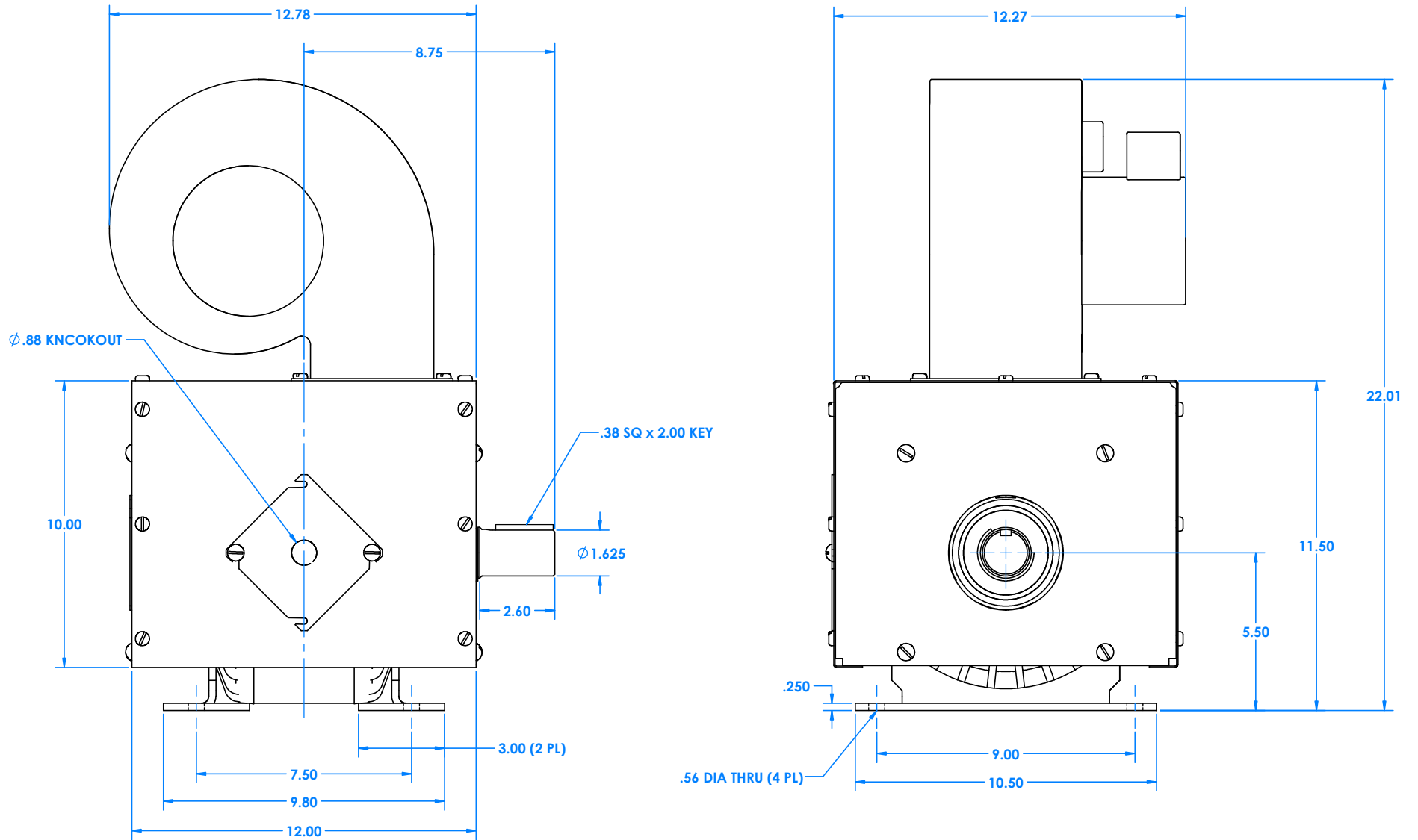

UNITS: INCHES

100MBA90B20

P/N 2960650-002

TYPE OF COOLING **FORCED AIR**
 MOUNTING **BASE**
 MAXIMUM SHAFT DEVIATION FROM HORIZONTAL **30°**

SPECIFICATIONS

TORQUE RANGE (LB. FT.) **1 - 100**
 SPEED RANGE (RPM) **0 - 3600**
 HEAT DISSIPATION (WATTS AT 1800 RPM) **1700**
 (HP AT 1800 RPM) **2.27**
 NON-EXCITED DRAG TORQUE (LB. FT.) MAX **1**
 WEIGHT LBS. (APPROX) **110**
 INERTIA - (LB. FT.²) - OUTER MEMBER **.68**

BLOWER DATA

115V AC, 1 Ph Frequency **50/60 Hz**
1/10 hp Current **2.05 A**

COIL DATA

VOLTS DC	COIL TEMPERATURE (°C)	RESISTANCE (OHMS)	RATED CURRENT (AMPS)	CURRENT TIME CONSTANT (SEC)	TORQUE TIME CONSTANT (SEC)
90	20	68	1	.6	.82

The time in seconds for current or torque to reach 63% of its final value after a step change in voltage is applied.

MODEL CODE

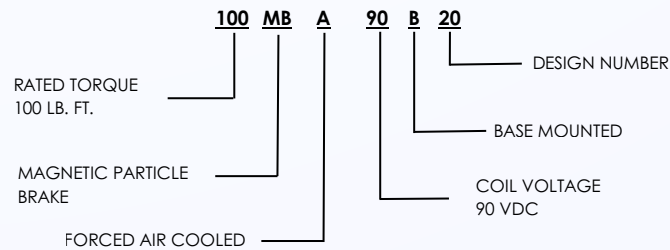

NOTE: The graph represents the average, continuous heat dissipation capacity of units operating under slip conditions. Slip watts can be calculated using the formula below. To ensure the life of the unit, it may be applied up to or below the curve.

$$\text{Slip watts} = \frac{\text{Torque} \times \text{RPM}}{7.04}$$

