

7MC90C

P/N 2960681-002

TYPE OF COOLING
MOUNTING
MAX. SHAFT DEVIATION FROM HORIZONTAL

AIR CONVECTION
NEMA 56C
30°

SPECIFICATIONS

TORQUE RANGE (LB. FT.) **.25 - 7**
SPEED RANGE (RPM) **0 - 3600**
HEAT DISSIPATION (WATTS AT 1800 RPM) **300**
(HP AT 1800 RPM) **.4**
NON-EXCITED DRAG TORQUE (LB. FT.) MAX **.25**
WEIGHT LBS. (APPROX.) **21**
MOMENTS OF INERTIA (LB. IN.²)
INNER MEMBER - 2.9
OUTER MEMBER - 4.7

COIL DATA

VOLTS DC	COIL TEMPERATURE (°C)	RESISTANCE (OHMS)	RATED CURRENT (AMPS)	CURRENT TIME CONSTANT (SEC)	TORQUE TIME CONSTANT (SEC)
90	20	257	.262	.11	.28

The time in seconds for current or torque to reach 63% of its final value after a step change in voltage is applied.

MODEL CODE

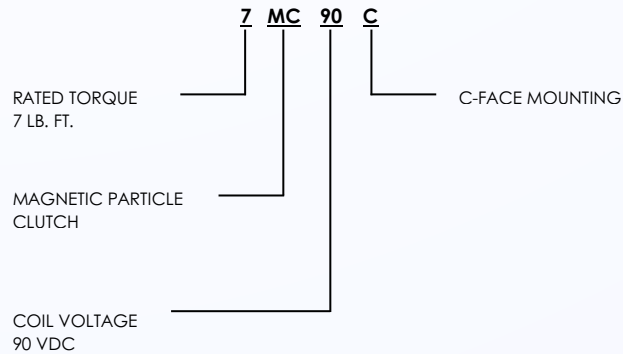

NOTE: The graph represents the average, continuous heat dissipation capacity of units operating under slip conditions. Slip watts can be calculated using the formula below. To ensure the life of the unit, it may be applied up to or below the curve. When referencing RPM on the graph, it is the speed of the outer rotating member not the motor speed.

$$\text{Slip watts} = \frac{\text{Torque} \times (\text{RPM in} - \text{RPM out})}{7.04}$$

TORQUE VS. COIL CURRENT

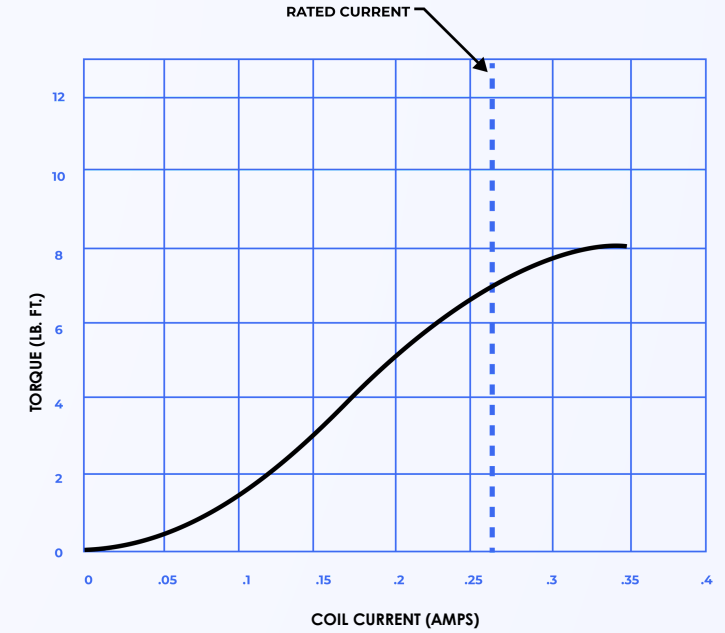

HEAT DISSIPATION VS. SPEED

