



MAGNE POWER

SERVICE PARTS INFORMATION

Magneclutch Magnetic Particle Clutch

MAGNECLUTCH

MODELS:

10MC90B20

10MCW90B20

10MCA90B20

10MC90F20



MODEL	REPAIR KIT	NOTE
10MC90B20	○ 2907729	METAL SHIELD OF BEARINGS MUST FACE IN, TOWARD EACH OTHER, WHEN ASSEMBLED
10MCW90B20	● 2907729	
10MC90F20	□ 2907922	

○ ● □ 0750360 MAGNETIC MEDIUM IS USED FOR BOTH THE FLANGE AND THE BASE MODELS.

▲ INNER ROTATING SUB ASS'Y 2947185 FOR BASE MODEL
2967175 FOR WATER COOLED BASE MODEL
2947176 FOR FLANGE MODEL
△ OUTER ROTATING SUB ASS'Y 2967137 FOR BASE MODEL AND
WATER COOLED BASE MODEL
2967302 FOR FLANGE MODEL

○ INCLUDED IN BASE MODEL
2907729 REPAIR KIT

● INCLUDED IN WATER COOLED
BASE MODEL 2907767 REPAIR KIT

□ INCLUDED IN FLANGE MODEL
2907922 REPAIR KIT

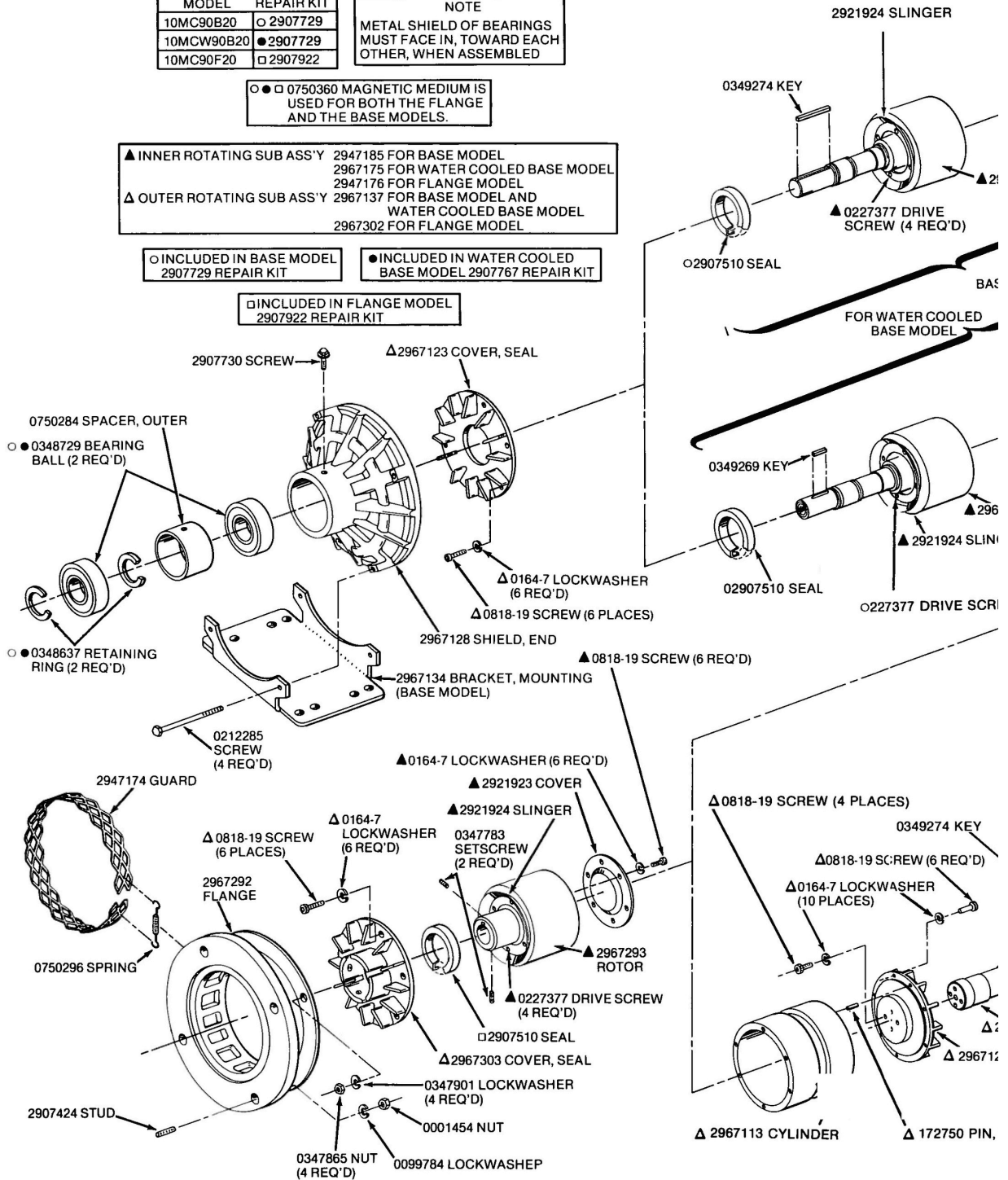

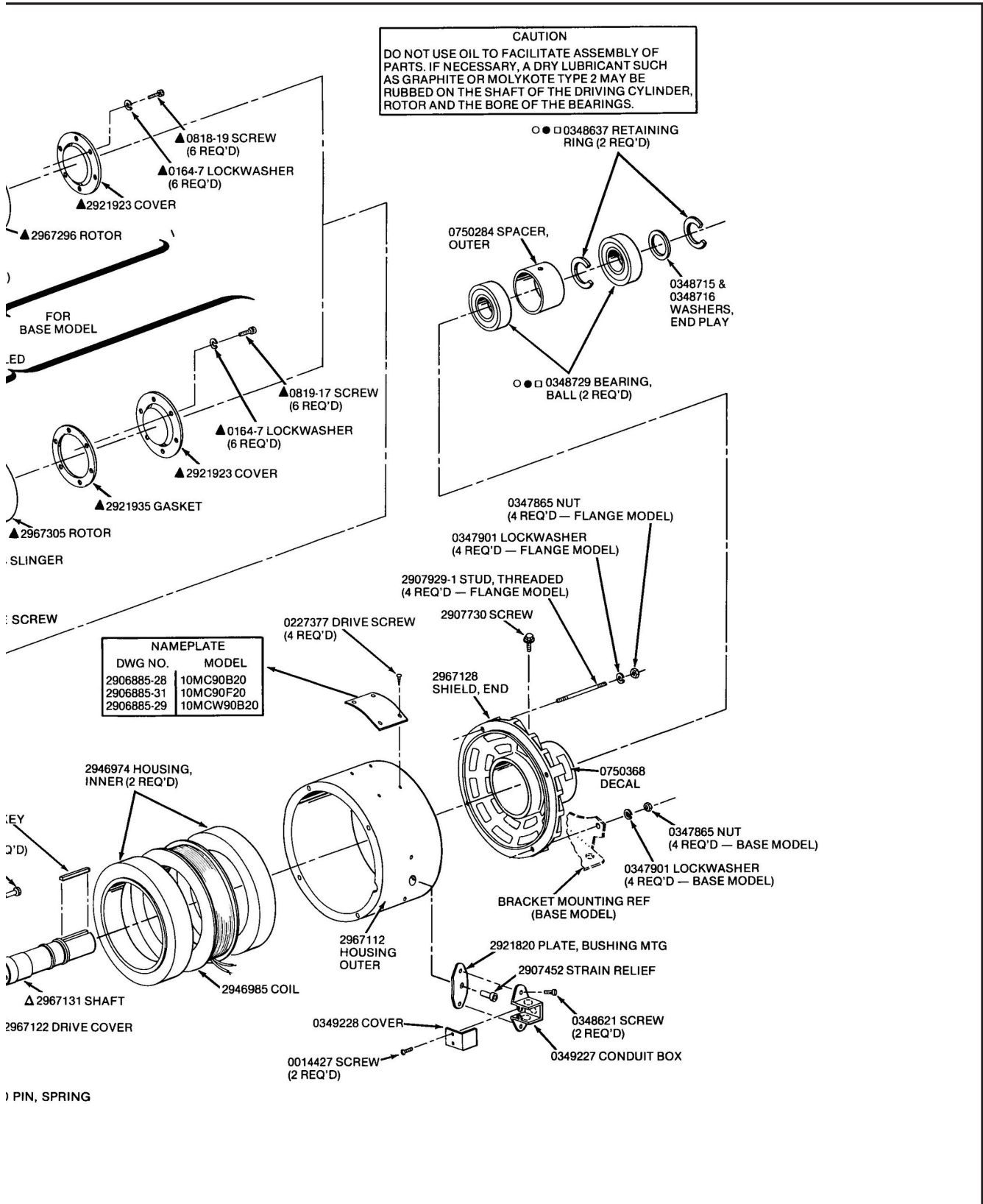

Model 10MCA90B

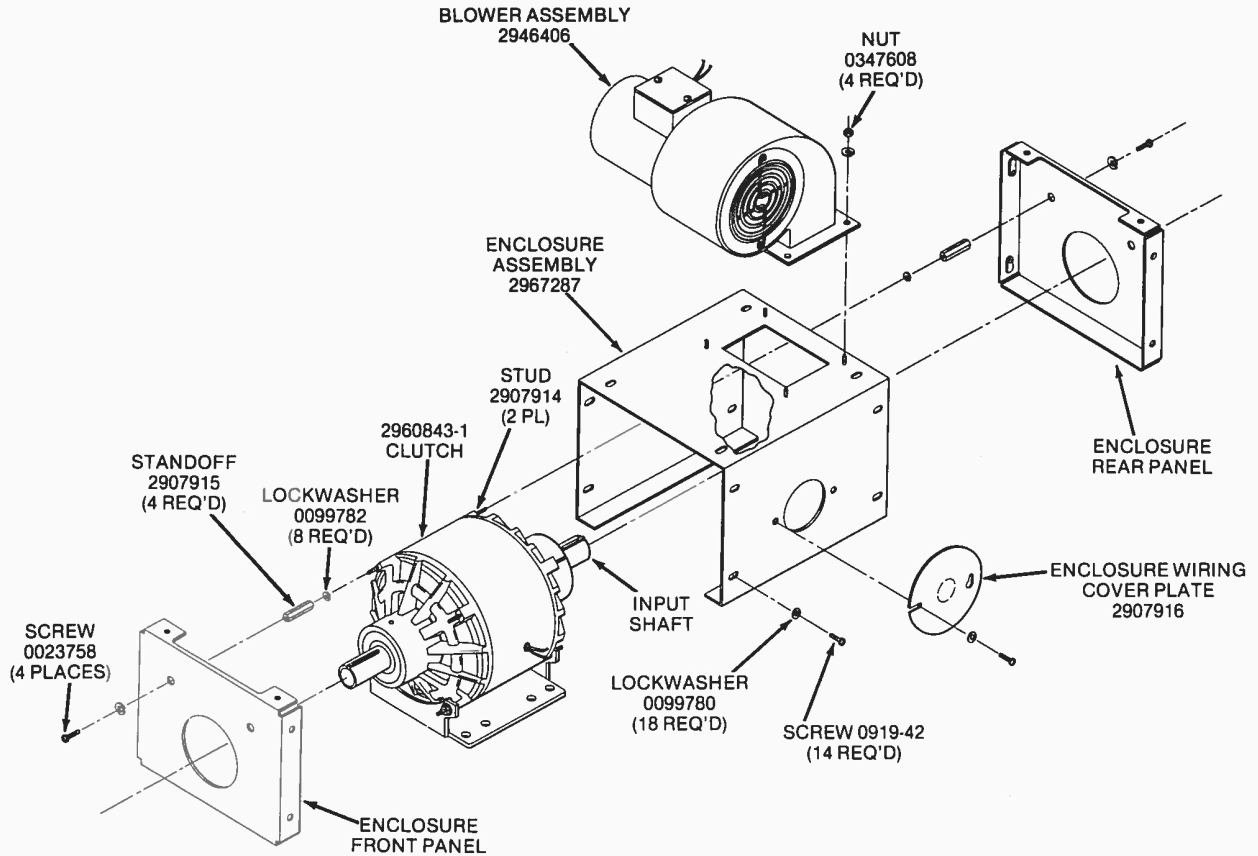

Model Code Breakdown

