

INSTALLATION GUIDE WATER COOLED MAGNECLUTCH & MAGNEBRAKE

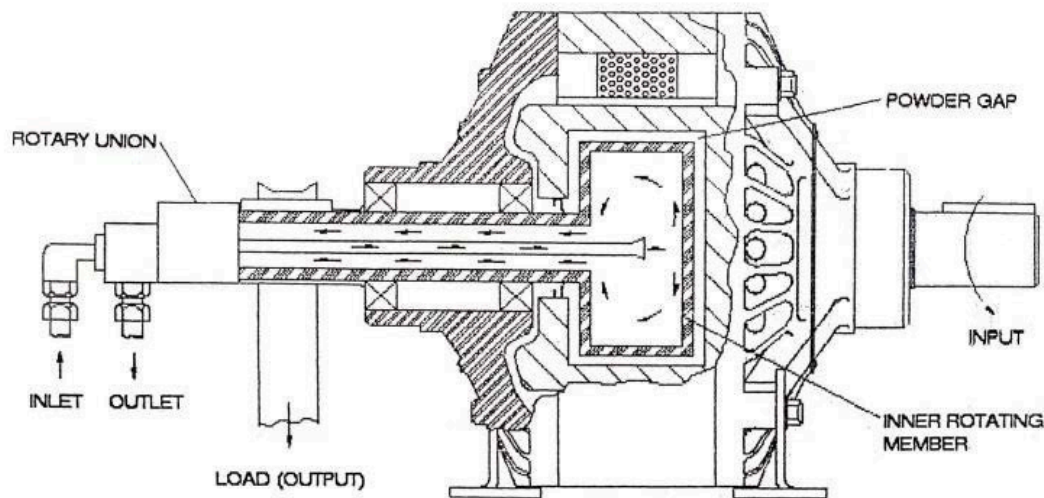

Figure 1 water cooled Magneclutch

Introduction: Water cooling is an effective and economical method to extend the rating and life of a Magneclutch or Magnebrake. Since heat is generated in the powder gap, efficient transfer of the heat is achieved by circulating water through the inner rotating member of the Magneclutch or Magnebrake. The Magneclutch requires a rotary union since the inner rotating member must rotate (See Figure 1). The Magnebrake does not require a rotary union because the inner rotating member of the brake is stationary.

Installation: The dimensions of the rotating union are shown in Figure 2 on page two. The user must provide the plumbing fittings and hoses to connect the rotary union to the water lines. The following instructions should be followed when installing the clutch.

- 1) No exterior bracing should be used to prevent the rotating union from turning.
- 2) Flexible hoses are recommended between the rotating union and the plant water lines. Since the Magneclutch and Magnebrake are often mounted on vibrating apparatus, the flexible hoses provide a buffer between the rigid plant water lines and the vibrating equipment. A 3/8 ID oil resistant hose, able to withstand a working pressure of 90 psi min. and at least 12" long, provides a good buffer.

3) Attach the flexible hoses to the rotary union before installing the rotary union in the Magneclutch. Clamp the rotary union in a vise while installing the hoses to prevent damage to the rotary union bearings. Use plumbing tape to seal all threaded connections.

4) Install the rotary union in the Magneclutch shaft.

5) Connect the flexible hoses to the plant water lines. The flexible hoses should not be taut when the installation is complete (i.e. the hoses should not put any load on the rotary union.)

The effectiveness of the water cooling option is maximized when the following recommendations are observed:

1) The cooling water flow should be limited to the rates specified in the table on page four and should never exceed 5 gpm. Rates higher than specified will not increase the Magneclutch or Magnebrake heat dissipation capacity, but instead cause cavitation and inconsistent cooling.

2) The outlet water temperature should be maintained above 68F and below 180F. The inlet water should be maintained above 60F. Colder inlet temperatures could cause condensation in the powder gap resulting in magnetic medium contamination.

3) The inlet water flow should be stopped when the Magneclutch or Magnebrake is shut down.

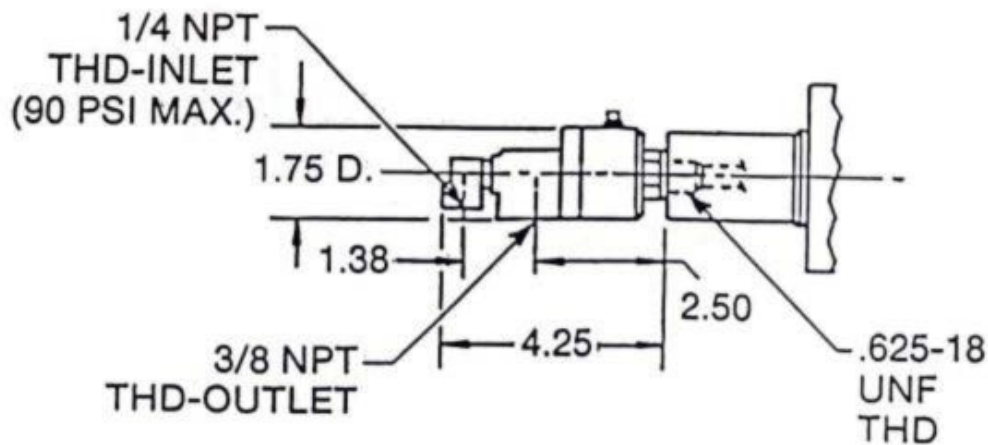

Figure 2 rotary union

To accomplish these operating parameters Magne recommends the system shown in Figure 3. The plumbing components shown will provide the maximum benefits from water cooling while minimizing potential problems. A list of these components is provided here to aid in obtaining them. No endorsement of the components or manufacturers is intended.

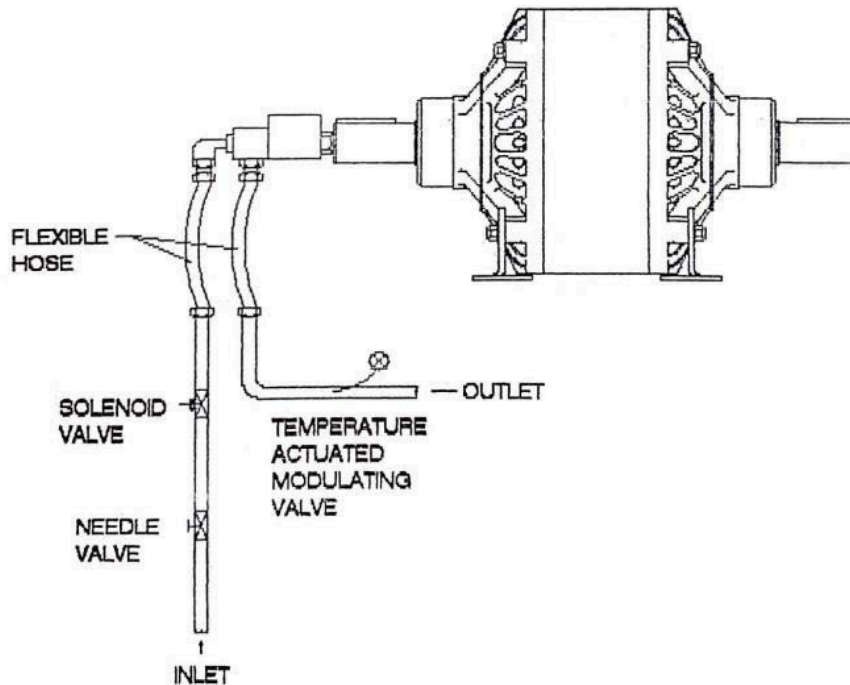

Figure 3 water cooled Magneclutch configuration

Needle Valve: The needle valve provides an economical and accurate method of closely regulating water flow. Excessive water flow can cause cavitation in the Magneclutch or Magnebrake. The needle valve will prevent inconsistent cooling.

Solenoid Valve: A 2-way solenoid valve is a popular cut-off valve for stopping water flow when the clutch or brake is shut down. Usually, the normally open type is preferred, and the orifice size is selected to match the water flow needs. A typical 2-way solenoid valve is the ASCO Red Hat Valve.

Temperature Actuated Modulating Valve: The modulating valve can help keep water warm which reduces condensation in the Magneclutch and Magnebrake. By using the bypass orifice, some water flow continues. This will avoid false temperature readings caused by stagnation. A typical temperature actuated modulating valve is the V47 Series “Penn Modulating Valve” by Johnson Controls.



Water coolers: When a closed water system is used, recirculation produces higher inlet water temperatures which greatly reduces condensation in the Magneclutch or Magnebrake. Recirculation means low make-up water costs, great flexibility in machine placement is achieved, and corrosion and freeze up protection may be accomplished with additives.

Specifications:

Max. inlet water pressure.....90 psi
Maximum speed.....3600 rpm

Model.....	Recommended Flow (gpm)
10MCW90B20.....	1
50MCW90B20.....	1
100MCW90B20.....	1
50MBW90B20.....	1
100MBW90B20.....	1