

50MC90F20 MAGNECLUTCH PERFORMANCE & OUTLINE

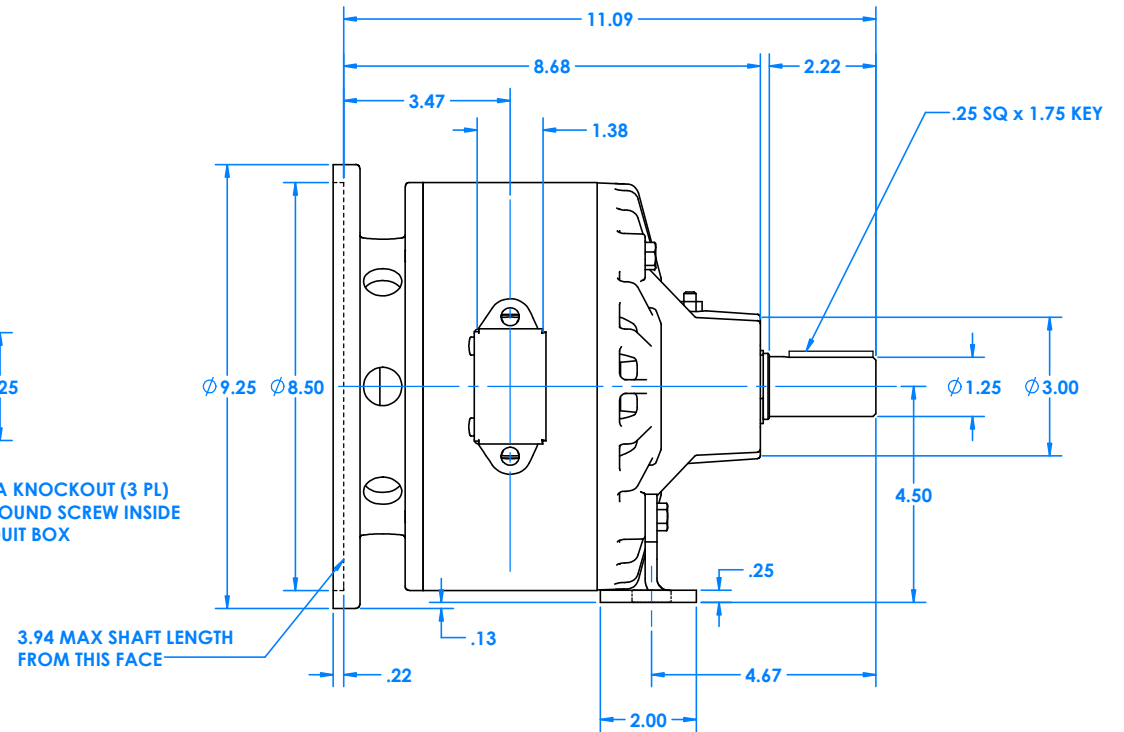

INSTALLATION NOTE:
 Align inner rotating member so that the face is positioned
 in line with the edge of the fins on the seal cover.

A-50 BORE ADAPTER REF
 TO ACCOMMODATE 1.125 DIA MOTOR SHAFTS

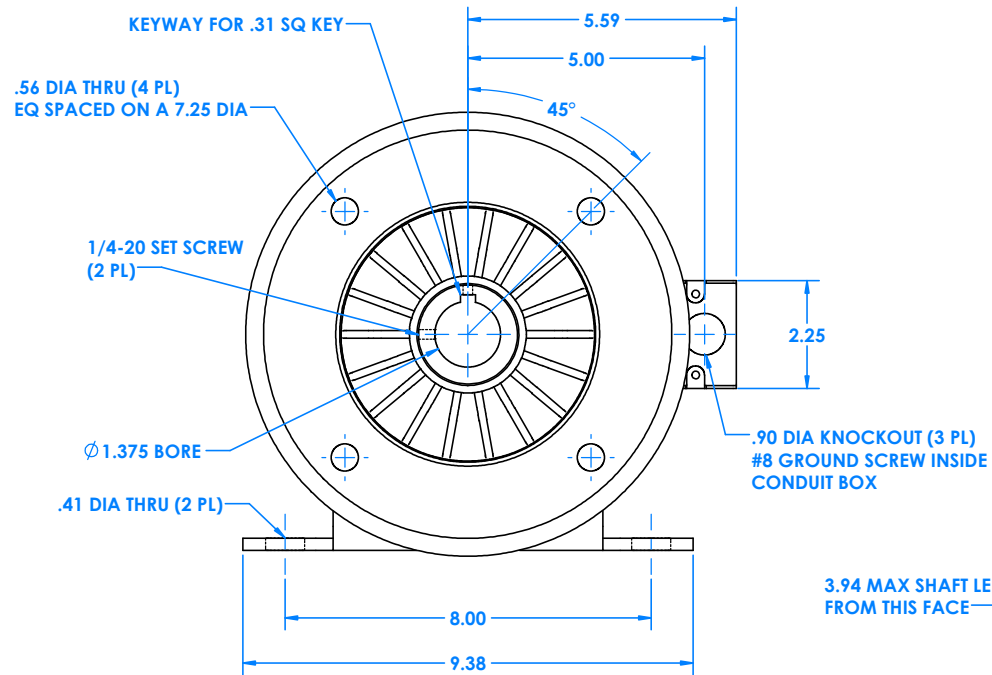
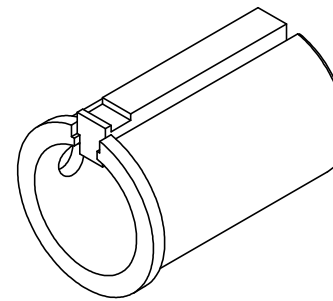

50MC90F20

P/N 0750351

TYPE OF COOLING

AIR CONVECTION

MOUNTING

**NEMA FRAMES 213TC AND 215TC
WITH A-50 ADAPTER NEMA FRAMES 182TC AND 184TC**

MAXIMUM SHAFT DEVIATION
FROM HORIZONTAL

30°

SPECIFICATIONS

| | |
|--|-----------------|
| TORQUE RANGE (LB. FT.) | .4 - 50 |
| SPEED RANGE (RPM) | 0 - 3600 |
| HEAT DISSIPATION (WATTS AT 1800 RPM) | 1050 |
| (HP AT 1800 RPM) | 1.41 |
| NON-EXCITED DRAG TORQUE (LB. FT.) MAX | .4 |
| WEIGHT LBS. (APPROX) | 61 |
| INERTIA - (LB. FT. ²) - OUTER MEMBER | .24 |
| - INNER MEMBER | .17 |

COIL DATA

| VOLTS DC | COIL TEMPERATURE (°C) | RESISTANCE (OHMS) | RATED CURRENT (AMPS) | CURRENT TIME CONSTANT (SEC) | TORQUE TIME CONSTANT (SEC) |
|-----------|-----------------------|-------------------|----------------------|-----------------------------|----------------------------|
| 90 | 20 | 127 | .53 | .22 | .38 |

The time in seconds for current or torque to reach 63% of its final value after a step change in voltage is applied.

MODEL CODE

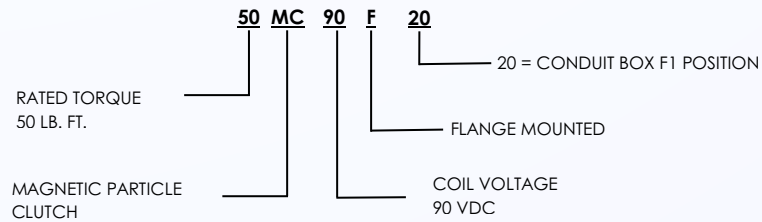

NOTE: The graph represents the average, continuous heat dissipation capacity of units operating under slip conditions. Slip watts can be calculated using the formula below. To ensure the life of the unit, it may be applied up to or below the curve. When referencing RPM on the graph, it is the speed of the outer rotating member not the motor speed.

$$\text{Slip watts} = \frac{\text{Torque} \times (\text{RPM in} - \text{RPM out})}{7.04}$$

